



service and maintenance procedures

DELUXE 4-WAY MULTIPOISE VARIABLE-CAPACITY DIRECT-VENT CONDENSING GAS FURNACE

355MAV

Series D

Cancels: SP05-35

SP05-39

6-98



A93040

NOTE: Read the entire instruction manual before performing any service or maintenance.

This symbol → indicates a change since the last issue.

Index	Page
SAFETY CONSIDERATIONS.....	1-2
ELECTROSTATIC DISCHARGE (ESD) PRECAUTIONS.....	2
GENERAL.....	2
CARE AND MAINTENANCE.....	2-11
Cleaning and/or Replacing Air Filter.....	2-3
Blower Motor and Wheel Maintenance.....	3-4
Cleaning Burners.....	4
Cleaning Heat Exchangers.....	4-5
Primary Heat Exchangers.....	4-5
Secondary Heat Exchangers.....	5
Flushing Collector Box and Drainage System.....	5-7
Servicing Hot Surface Ignitor.....	7
Electrical Controls and Wiring.....	7-8
Troubleshooting.....	8-9
Checking Heat Tape Operation (If Applicable).....	10
Winterizing.....	10-11
SERVICE LABEL.....	12-13
WIRING DIAGRAM.....	14

SAFETY CONSIDERATIONS

Installing and servicing heating equipment can be hazardous due to gas and electrical components. Only trained and qualified personnel should install, repair, or service heating equipment.

Untrained personnel can perform basic maintenance functions such as cleaning and replacing air filters. All other operations must be performed by trained service personnel. When working on heating equipment, observe precautions in the literature, on tags, and on labels attached to or shipped with the unit and other safety precautions that may apply.

Follow all safety codes, including NFPA 54/ANSI Z223.1-1996, National Fuel Gas Code and ANSI/NFPA 90B, Installation Standards, Warm Air Heating and Air Conditioning Systems. In Canada, refer to the current edition of the National Standard of Canada CAN/CGA-B-149. Wear safety glasses and work gloves. Have a fire extinguisher available during start-up and adjustment procedures and service calls.



As an ENERGY STARSM Partner, Bryant Heating & Cooling Systems has determined that this product meets the ENERGY STAR guidelines for energy efficiency.

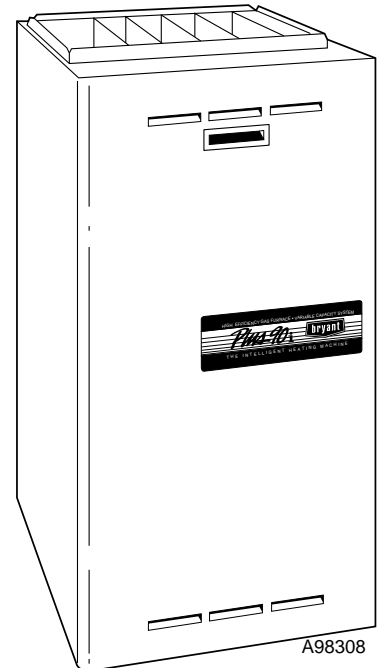

A98308



CERTIFICATE NO. FM 29652

APPROVALS
ISO 9001
EN 29001
BS 5750 PART 1
ANSI/ASQC Q91

REGISTERED QUALITY SYSTEM

Fig. 1—Multipoise Furnace in Upflow Orientation

Recognize safety information. This is the safety-alert symbol . When you see this symbol on the unit and in instructions or manuals, be alert to the potential for personal injury.

Understand the signal words DANGER, WARNING, and CAUTION. These words are used with the safety-alert symbol. DANGER identifies the most serious hazards which **will** result in severe personal injury or death. WARNING signifies hazards which **could** result in personal injury or death. CAUTION is used to identify unsafe practices which **would** result in minor personal injury or product and property damage. NOTE is used to highlight suggestions which **will** result in enhanced installation, reliability, or operation.



WARNING: The ability to properly perform maintenance on this equipment requires certain expertise, mechanical skills, tools, and equipment. If you do not possess these, do not attempt to perform any maintenance on this equipment other than those procedures recommended in the User's Manual. FAILURE TO FOLLOW THIS WARNING COULD RESULT IN POSSIBLE DAMAGE TO THIS EQUIPMENT, SERIOUS PERSONAL INJURY, OR DEATH.

WARNING: Never store anything on, near, or in contact with the furnace, such as:

1. Spray or aerosol cans, rags, brooms, dust mops, vacuum cleaners, or other cleaning tools.
2. Soap powders, bleaches, waxes or other cleaning compounds, plastic or plastic containers, gasoline, kerosene, cigarette lighter fluid, dry cleaning fluids, or other volatile fluids.
3. Paint thinners and other painting compounds, paper bags, or other paper products. Failure to follow this warning can cause corrosion of the heat exchanger, fire, personal injury, or death.

ELECTROSTATIC DISCHARGE (ESD) PRECAUTIONS

CAUTION: Electrostatic discharge can affect electronic components. Take precautions during furnace installation and servicing to protect the furnace electronic control. Precautions will prevent electrostatic discharges from personnel and hand tools which are held during the procedure. These precautions will help to avoid exposing the control to electrostatic discharge by putting the furnace, the control, and the person at the same electrostatic potential.

1. Disconnect all power to the furnace. **DO NOT TOUCH THE CONTROL OR ANY WIRE CONNECTED TO THE CONTROL PRIOR TO DISCHARGING YOUR BODY'S ELECTROSTATIC CHARGE TO GROUND.**
2. Firmly touch a clean, unpainted, metal surface of the furnace chassis which is close to the control. Tools held in a person's hand during grounding will be satisfactorily discharged.
3. After touching the chassis you may proceed to service the control or connecting wires as long as you do nothing that recharges your body with static electricity (for example; **DO NOT** move or shuffle your feet, **DO NOT** touch ungrounded objects, etc.).
4. If you touch ungrounded objects (recharge your body with static electricity), firmly touch furnace again before touching control or wires.
5. Use this procedure for installed and uninstalled (ungrounded) furnaces.
6. Before removing a new control from its container, discharge your body's electrostatic charge to ground to protect the control from damage. If the control is to be installed in a furnace, follow items 1 through 5 before bringing the control or yourself into contact with the furnace. Put all used **AND** new controls into containers before touching ungrounded objects.
7. An ESD service kit (available from commercial sources) may also be used to prevent ESD damage.

GENERAL

These instructions are written as if the furnace is installed in an upflow application. An upflow furnace application is where the blower is located below the combustion and controls section of the furnace, and conditioned air is discharged upward. Since this furnace can be installed in any of the 4 positions shown in Fig. 2, you must revise your orientation to component location accordingly.

CARE AND MAINTENANCE

For continuing high performance and to minimize possible equipment failure, it is essential that maintenance be performed annually on this equipment. Consult your local dealer for maintenance and maintenance contract availability.

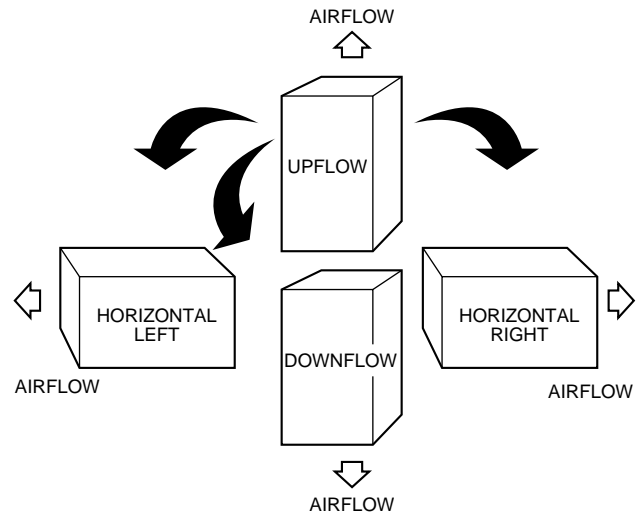

A93041

Fig. 2—Multipoise Orientations

WARNING: Turn off the gas and electrical supplies to the unit before performing any maintenance or service. Follow the operating instructions on the label attached to the furnace. Failure to follow this warning could result in personal injury or death.

The minimum maintenance that should be performed on this equipment is as follows:

1. Check and clean or replace air filter each month as required.
2. Check blower motor and wheel for cleanliness annually.
3. Check electrical connections for tightness and controls for proper operation each heating season. Service as necessary.
4. Check for proper condensate drainage. Clean as necessary.
5. Check for blockages in combustion-air and vent pipes annually.
6. Check burners for cleanliness annually.

CAUTION: Personal injury could result from sharp metal edges, etc. Use care when removing parts.

I. CLEANING AND/OR REPLACING AIR FILTER

The air filter arrangement may vary depending on the application or orientation.

CAUTION: Never operate unit without a filter or with the blower access panel removed. Failure to follow this warning could result in a fire or personal injury.

To clean or replace the filters, proceed as follows:

1. Turn off electrical supply to furnace.
2. Remove main furnace door and blower access panel.
3. Release filter retainer wire. (See Fig. 3 and 4.)
4. Slide filter out of furnace.
5. Furnaces are equipped with permanent, washable filter(s). Clean filter by spraying cold tap water through filter in opposite direction of airflow.
6. Rinse filter and let dry. Oiling or coating of filter is not recommended.
7. Slide filter into furnace.

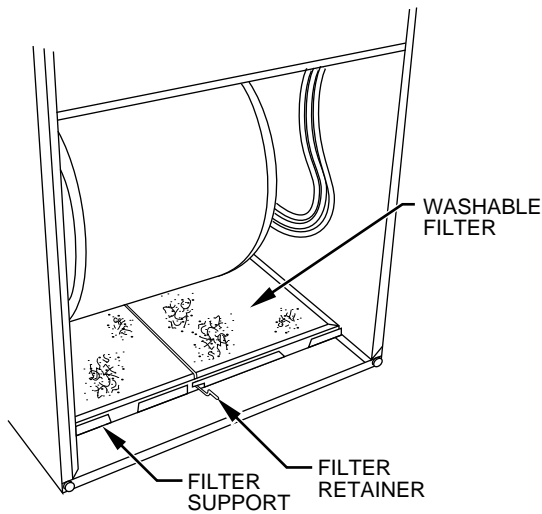

Fig. 3—Bottom Filter Arrangement

8. Recapture filter retainer wire.
9. Replace blower access panel and main furnace door.
10. Turn on electrical supply to furnace.

NOTE: If the filter has cross-mesh binding, the binding must face the blower. If the filter has an air direction arrow, the arrow must point toward the blower.

II. BLOWER MOTOR AND WHEEL MAINTENANCE

To ensure long life, economy, and high efficiency, clean accumulated dirt and grease from blower wheel and motor annually.

The inducer and blower motors are pre-lubricated and require no additional lubrication. These motors can be identified by the absence of oil ports on each end of the motor.

The following items should be performed by a qualified service technician.

Clean blower motor and wheel as follows:

1. Turn off electrical supply to furnace.
2. Remove main furnace door and blower access panel.
3. Disconnect wires.
 - a. Disconnect motor wiring harness plug on blower housing.
 - b. Disconnect auxiliary limit switch leads at switch.
 - c. Disconnect field thermostat connections depending on their length and routing.
4. Position control box, transformer, and door switch assembly to right side of furnace casing.
5. If condensate trap is located in left- or right-hand side of furnace casing, proceed to item 6, otherwise remove trap and tubing as described below.
 - a. Disconnect field drain connection from condensate trap.
 - b. Disconnect drain and relief port tubes from condensate trap.
 - c. Remove condensate trap from blower shelf.
6. Remove screws securing blower assembly to blower shelf and slide blower assembly out of furnace.
7. Clean blower wheel and motor by using a vacuum with soft brush attachment. Be careful not to disturb balance weights (clips) on blower wheel vanes. Do not bend wheel or blades as balance will be affected.
8. If greasy residue is present on blower wheel, remove wheel from the blower housing and wash it with an appropriate degreaser. To remove wheel:

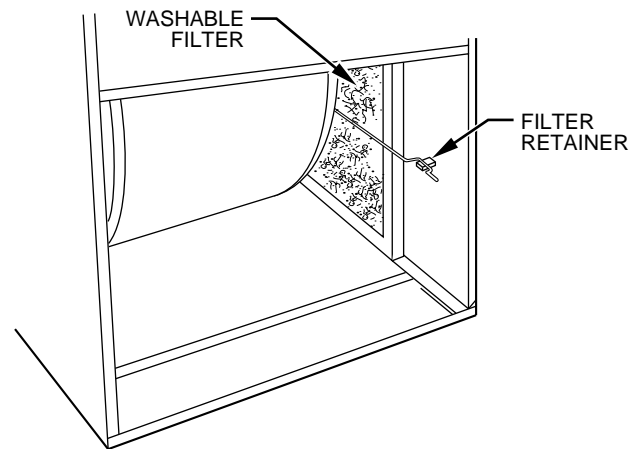

Fig. 4—Filter Installed for Side Inlet

- a. Mark blower wheel location on shaft before disassembly to ensure proper reassembly.
- b. Loosen setscrew holding blower wheel on motor shaft.

NOTE: Mark blower mounting arms and blower housing so each arm is positioned at the same hole location during reassembly.

- c. Mark blower wheel orientation and cutoff plate location to ensure proper reassembly.
- d. Remove screws securing cutoff plate and remove cutoff plate from housing.
- e. Remove bolts holding motor mounts to blower housing and slide motor and mounts out of housing.
- f. Remove blower wheel from housing.
- g. Clean wheel per instructions on degreaser cleaner.
9. Reassemble motor and blower wheel by reversing items 8b through 8f. Ensure wheel is positioned for proper rotation.
10. Reinstall blower assembly in furnace.
11. Reinstall condensate trap and tubing if previously removed.
 - a. Reinstall condensate trap in hole in blower shelf.
 - b. Connect condensate trap drain tubes. See Fig. 8 or tubing diagram on main furnace door for proper tube location.
 - (1.) Connect 1 tube (blue or blue and white striped) from collector box.
 - (2.) Connect 1 tube (violet or unmarked) from inducer housing.
 - (3.) Connect 1 tube (relief port, green or pink) from collector box.
 - c. Connect field drain to condensate trap.

NOTE: Ensure tubes are not kinked or pinched, as this will affect operation.

12. Reinstall control box, transformer, and door switch assembly on blower shelf.
13. Reconnect wires.
 - a. Refer to furnace wiring diagram, and connect motor and auxiliary limit switch leads. (See Fig. 16.)
 - b. Connect thermostat leads if previously disconnected.
14. Turn on electrical supply. Manually close blower access panel door switch. Use a piece of tape to hold switch closed. Check for proper rotation and speed changes between heating and cooling by jumpering R to G and R to Y on control center thermostat terminals. (See Fig. 11.)

A93046

A93045

WARNING: Blower access panel door switch opens 115-v power to control center. No component operation can occur. Caution must be taken when manually closing this switch for service purposes. Failure to follow this warning could result in personal injury or death.

- If furnace is operating properly, release blower access panel door switch, replace blower access panel, and replace main furnace door.

III. CLEANING BURNERS

The following items should be performed by a qualified service technician. If the burners develop an accumulation of light dirt or dust, they may be cleaned by using the following procedure:

- Turn off gas and electrical supplies to furnace.
- Remove main furnace door.
- Remove burner box cover.
- Using backup wrench, disconnect gas supply pipe from gas valve.

CAUTION: Label all wires prior to disconnection when servicing controls. Wiring errors can cause improper and dangerous operation.

- Remove wires from gas valve. Note location for reassembly.
- Remove burner box pressure tube from gas valve regulator fitting.
- Remove screws that secure manifold to burner box. (See Fig. 5.)

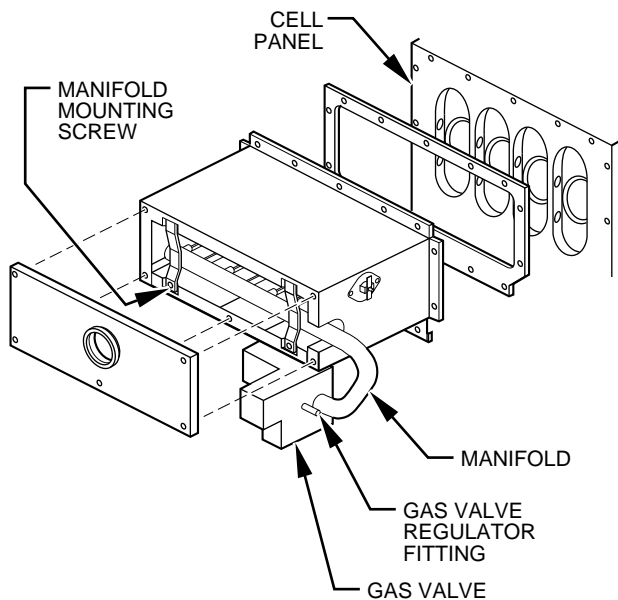

A96304

Fig. 5—Burner Box Assembly

- Remove manifold, orifices, and gas valve as 1 assembly.
- Remove screws attaching burner assembly in burner box.
- Remove burner assembly from burner box.

NOTE: All burners are attached to burner bracket and can be removed as 1 assembly.

- Clean burners with soft brush and vacuum.
- Reinstall manifold, orifice, and gas valve assembly in burner box. Ensure manifold seal grommet is installed properly and burners fit over orifices.

- Reconnect wires to gas valve. Refer to furnace wiring diagram for proper wire location.
- Reinstall burner box pressure tube to gas valve regulator fitting.
- Reinstall gas supply pipe to gas valve using backup wrench on gas valve to prevent rotation and improper orientation.

NOTE: Use propane gas resistant pipe dope to prevent gas leaks. DO NOT use Teflon tape.

WARNING: Gas valve knob or switch MUST be facing forward or tilted upward. Failure to follow this warning could result in property damage, personal injury, or death.

- Replace burner box cover.
- Turn on gas and electrical supplies to furnace.
- Check for gas leaks.

WARNING: Never use matches, candles, flame, or other sources of ignition to check for gas leakage. Use a soap-and-water solution. Failure to follow this warning could result in a fire, personal injury, or death.

- Replace main furnace door.

IV. CLEANING HEAT EXCHANGERS

The following items should be performed by a qualified service technician.

A. Primary Heat Exchangers

If the heat exchangers get an accumulation of light dirt or dust on the inside, they may be cleaned by the following procedure:

NOTE: If the heat exchangers get a heavy accumulation of soot and carbon, both the primary and secondary heat exchangers should be replaced rather than trying to clean them thoroughly due to their intricate design. A build-up of soot and carbon indicates that a problem exists which needs to be corrected, such as improper adjustment of manifold pressure, insufficient or poor quality combustion air, improper vent termination, incorrect size or damaged manifold orifice(s), improper gas, or a restricted heat exchanger (primary or secondary). Action must be taken to correct the problem.

- Turn off gas and electrical supplies to furnace.
- Remove main furnace door.

CAUTION: Label all wires prior to disconnection when servicing controls. Wiring errors can cause improper and hazardous operation.

- Disconnect wires or connectors to rollout switch, gas valve, ignitor, and flame sensor.
- Disconnect combustion-air intake pipe from intake housing.
- Remove the pressure switch tube from intake housing.
- Remove screws attaching intake housing to burner box, and rotate intake housing away from burner box for removal.
- Using backup wrench, disconnect gas supply pipe from gas valve.
- Disconnect pressure tubing from gas valve.
- Remove 2 screws attaching top filler panel and rotate upwards to gain access to screws attaching burner box to cell panel.

- Remove screws attaching burner box to cell panel. (See Fig. 5.)

NOTE: Burner box, cover, manifold, gas valve, and burner assembly should be removed as 1 assembly.

- Clean heat exchanger openings with a vacuum and a soft brush. (See Fig. 6.)

NOTE: After cleaning, inspect the heat exchangers to ensure they are free of all foreign objects that may restrict flow of combustion products.

- Reverse items 4 through 10 for reassembly.

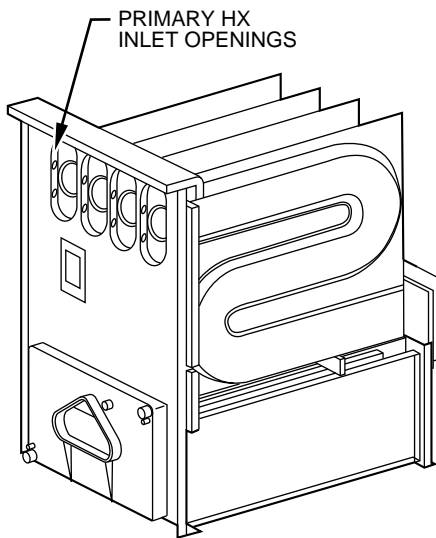

A96305

Fig. 6—Cleaning Inlet Openings of Primary Heat Exchangers

⚠	WARNING: The ground wire from the gas valve MUST be attached to the burner box attachment screw. Failure to attach this ground wire to an adequate casing ground will cause the furnace control to lock out.
---	--

NOTE: Be sure burner box gasket is installed between burner box and cell panel. If gasket is damaged, replace it.

→ **NOTE:** Inspect combustion-air intake housing. If foamed gasket was removed, check for any damage. If gasket is damaged in any way, it must be repaired. To repair, remove damaged gasket section, apply sealant releasing agent such as PAM cooking spray or equivalent (must not contain corn or canola oil, aromatic or halogenated hydrocarbons or inadequate seal may occur) to burner box and apply a small bead of G.E. RTV 162, G.E. RTV 6702, or Dow-Corning RTV 738 sealant to edge of combustion-air intake housing. (See Fig. 7.)

- Refer to furnace wiring diagram and connect wires to rollout switch, gas valve, ignitor, and flame sensor.
- Reconnect pressure switch tubes to gas valve and intake housing. Refer to tube routing label on main furnace door or Fig. 8 for proper tube location. Be sure tubes are not kinked.
- Turn on gas and electrical supplies to furnace.
- Check furnace operation through 2 complete heat operating cycles. Look through sight glass in burner enclosure to check burners. Burner flames should be clear blue, almost transparent. (See Fig. 9.)
- Check for gas leaks.

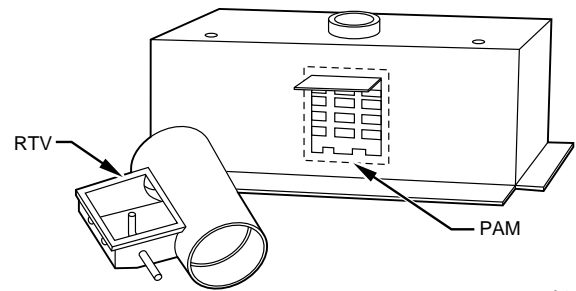

A93087

Fig. 7—Combustion-Air Intake Housing Gasket Repair

⚠	WARNING: Never use matches, candles, flame, or other sources of ignition to check for gas leakage. Use a soap-and-water solution. Failure to follow this warning could result in a fire, personal injury, or death.
---	--

- Replace main furnace door.

B. Secondary Heat Exchangers

NOTE: The condensing side (inside) of the secondary heat exchangers **CANNOT** be serviced or inspected. A small number of bottom outlet openings can be inspected by removing the inducer assembly. See Flushing Collector Box and Drainage System section for details on removing inducer assembly.

V. FLUSHING COLLECTOR BOX AND DRAINAGE SYSTEM

- Turn off gas and electrical supplies to furnace.
- Remove main furnace door.
- Disconnect inducer motor and pressure switch wires or connectors.
- Disconnect pressure switch tubes.
- Disconnect vent pipe from inducer housing outlet by loosening clamp.
- Disconnect drain tube from inducer housing. (See Fig. 8.)
- Remove inducer housing assembly by removing 4 bolts attaching assembly to cell panel.
- Flush inside of collector box with water until discharge from condensate trap is clean and runs freely.

NOTE: Ensure the drain tube disconnected from the inducer housing is higher than the collector box opening or water will flow out tube.

- Inspect inside area of collector box for any pieces of foreign materials and remove if present.

⚠	CAUTION: DO NOT use wire brush or other sharp object to inspect or dislodge materials in secondary heat exchangers as failure of the secondary heat exchanger will occur. Flush with water only.
---	--

- Reassemble inducer assembly by reversing items 5 through 7.

→ **NOTE:** If seal between the inducer housing and the collector box is damaged in any way, it must be repaired. To repair, apply sealant releasing agent such as PAM cooking spray or equivalent (must not contain corn or canola oil, aromatic or halogenated hydrocarbons or inadequate seal may occur) to inducer housing. (See Fig. 10.) Apply a small bead of G.E. RTV 162, G.E. RTV 6702, or Dow-Corning RTV 738 sealant to groove in collector box.

- Refer to furnace wiring diagram and connect wires to inducer motor and pressure switches or connectors.

INSTALLATION

This appliance requires a special venting system. Refer to the installation instructions for parts list and method of installation. Furnace must be installed level, or pitched forward within 1/2 inch of level for proper drainage. Failure will result in equipment or property damage. See Installation Manual for IMPORTANT unit support details on horizontal applications.

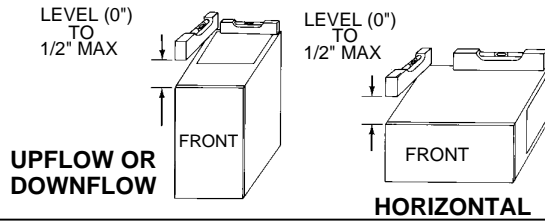

Furnace is shipped from factory in upflow configuration. Pressure tube and drain tube routing MUST match the diagrams below.

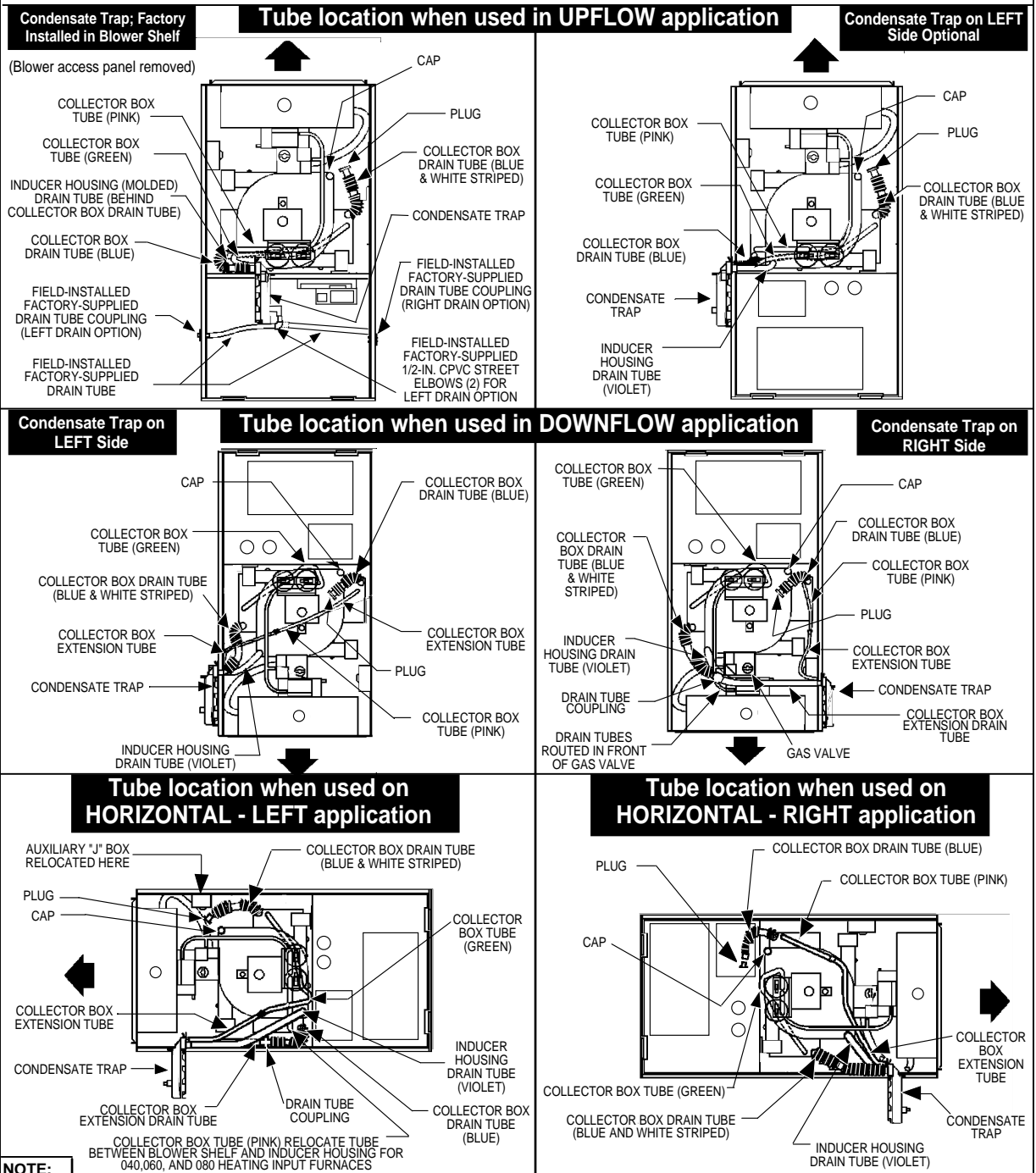

- NOTE:**
1. All tubing must be connected securely and routed to avoid kinks and traps.
 2. Pressure tubing must always slope away from pressure switch to collector box connection as shown.
 3. HORIZONTAL-LEFT installations require the collector box pressure tube to be relocated between the inducer housing and the blower shelf to prevent a trap. Refer to the Installation Instructions for further details.
- 322094-101 REV. B

Fig. 8—Furnace Pressure and Drain Tubing Diagram

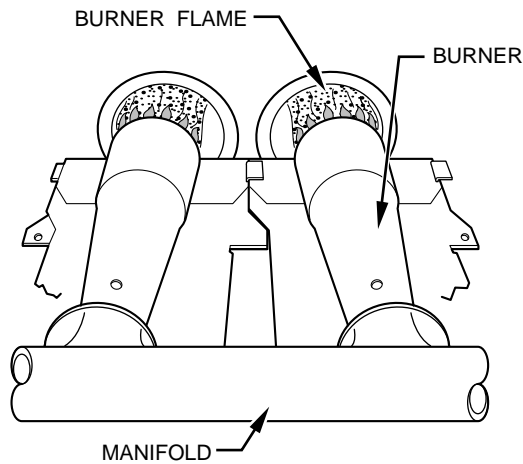

Fig. 9—Burner Flame

A89020

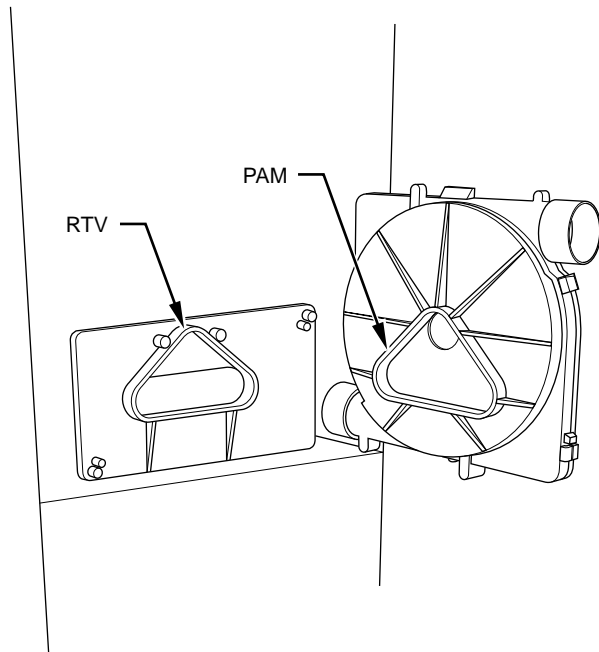

Fig. 10—Gasket on Collector Box

A93081

12. Reconnect pressure tubes to pressure switches. See diagram on main furnace door for proper location of tubes. Be sure tubes are not kinked. (See Fig. 8.)
13. Turn on gas and electrical supplies to furnace.
14. Check furnace operation through 2 complete heat operating cycles. Check area below inducer housing, vent pipe, and condensate trap to ensure no condensate leaks occur. If leaks are found, correct the problem.
15. Check for gas leaks.

WARNING: Never use matches, candles, flame, or other sources of ignition to check for gas leakage. Use a soap-and-water solution. Failure to follow this warning could result in a fire, personal injury, or death.

16. Replace main furnace door.

VI. SERVICING HOT SURFACE IGNITOR

The ignitor does NOT require annual inspection. Check ignitor resistance before removal.

1. Turn off gas and electrical supplies to furnace.
2. Remove main furnace door.
3. Disconnect ignitor wire connection.
4. Check ignitor resistance.
 - a. Using an ohm meter, check resistance across both ignitor leads in connector.
 - b. Cold reading should be between 45 ohms and 90 ohms.
 - c. If ohm reading is higher than 110 ohms, ignitor is cracked and must be replaced.
5. Remove ignitor assembly.

CAUTION: Allow ignitor to cool before removal. Normal operation temperatures exceed 2000°F.

- a. Do not remove ignitor from bracket while assembly is in furnace. Using a 1/4 in. nutdriver, remove screw securing bracket and ignitor assembly to bottom of burner box. The screw in the bracket is always located toward outside of burner box. The screw may be hidden by inlet box or inlet pipe, but can be removed without removing either. After removing screw, slide ignitor and bracket toward outside of burner box and pull straight out.

CAUTION: The ignitor is fragile. DO NOT allow it to hit the side of the burner box opening while removing or replacing it.

- b. Inspect ignitor for a white area indicating a crack may be present. If found, replace ignitor.

NOTE: A small crack cannot be seen on a new ignitor. After a period of operation, a white area will be visible around the crack.

- c. If replacement is required, replace ignitor on ignitor bracket external to furnace to avoid damage as the silicon portion is very brittle and will easily crack or shatter.

- d. To remove ignitor from ignitor bracket, remove screw holding ignitor ceramic block to bracket and pull ceramic block out of bracket.

6. To replace ignitor/ignitor assembly, reverse items 5a through 5d.
7. Reconnect ignitor wire connection.
8. Turn on gas and electrical supplies to furnace.
9. Verify ignitor operation by initiating control board self-test feature or by cycling thermostat.
10. Replace main furnace door.

VII. ELECTRICAL CONTROLS AND WIRING

CAUTION: There may be more than 1 electrical supply to the unit. Check accessories and cooling unit for additional electrical supplies.

The electrical ground and polarity for 115-v wiring must be maintained properly. Refer to Fig. 11 for field wiring information and to Fig. 16 for unit wiring information.

NOTE: If the polarity is not correct, the STATUS LED on the control center will flash rapidly and prevent the furnace from operating. The control system also requires an earth ground for proper operation of the control center and flame sensing.

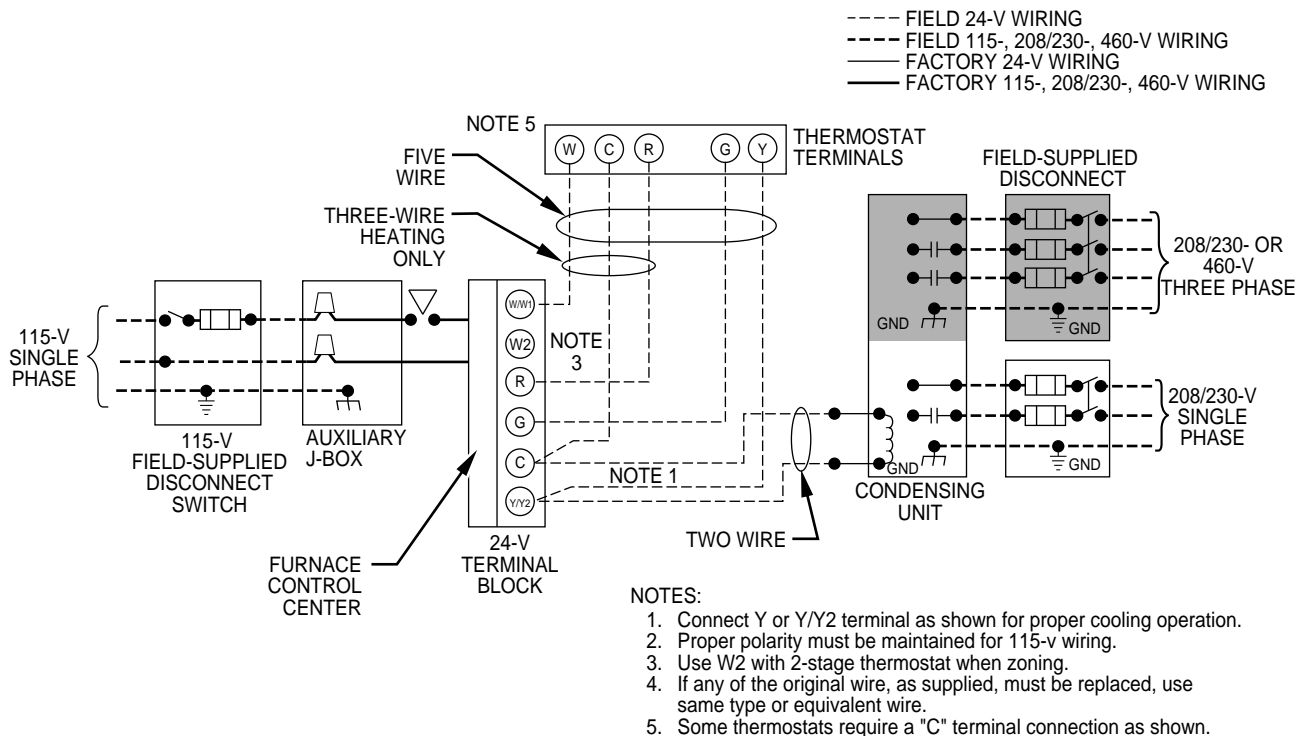

A98325

→ Fig. 11—Field Wiring

The 24-v circuit contains an automotive-type, 3-amp fuse located on the control center. (See Fig. 12.) Any direct shorts of the 24-v wiring during installation, service, or maintenance will cause this fuse to blow. If fuse replacement is required, use ONLY a fuse of identical size.

With power to the unit disconnected, check all electrical connections for tightness. Tighten all screws on electrical connections. If any smoky or burned connections are found, disassemble the connection, clean all parts, strip wire, and reassemble properly and securely.

Reconnect electrical supply to unit and observe unit through 1 complete operating cycle. Electrical controls are difficult to check without proper instrumentation; if there are any discrepancies in the operating cycle, contact your dealer and request service.

VIII. TROUBLESHOOTING

For an explanation of fault codes, refer to service label located on back of main furnace door or Fig. 15.

The control center stores all fault codes for a period of 5 "good or proper" operating cycles, regardless of 115- or 24-v power interruption.

NOTE: Removing blower access panel opens blower access panel door switch and terminates 115-v power to control center. Look into blower access panel sight glass for current LED status.

1. To retrieve fault code proceed with the following:

NOTE: NO thermostat signal may be present at control center and all blower time delay off periods must be completed.

- a. Leave 115-v power to furnace turned on.
- b. Remove main furnace door.
- c. Look into blower access panel sight glass for current LED status.
- d. Remove blower access panel.
- e. Turn setup switch SW-1 to ON position. (See Fig. 12 or 16 for location.)
- f. Manually close blower access panel door switch. Use a piece of tape to hold switch closed.

WARNING: Blower access panel door switch opens 115-v power to control center. No component operation can occur. Caution must be taken when manually closing this switch for service purposes. Failure to follow this warning could result in personal injury or death.

- g. LEDs display last fault code to occur first, followed by any other fault that has occurred in the last 5 "good or proper" cycles. The remaining faults displayed will be in numerical order starting from the lowest number first. Only 1 of each fault code will be displayed, regardless of how many times the fault has occurred.
 - h. Fault code display will continue and repeat as described above or until setup switch SW-1 is turned off.
 - i. Release blower access panel door switch and replace blower access panel.
 - j. Operate furnace through 1 heat cycle to test for proper operation and check LED status.
 - k. If furnace is operating properly and LEDs indicate proper operation, replace main furnace door.
2. Fault code display can be removed from control's display mode by performing the following. This is also called the "Clean Up Procedure."
 - a. Leave 115-v power to furnace turned on.
 - b. Remove main furnace door.
 - c. Look into blower access panel sight glass for current LED status.
 - d. Remove blower access panel.
 - e. Turn setup switch SW-1 to ON position. (See Fig. 12 or 16 for location.)
 - f. Jumper thermostat terminals R, W, and Y on control center.

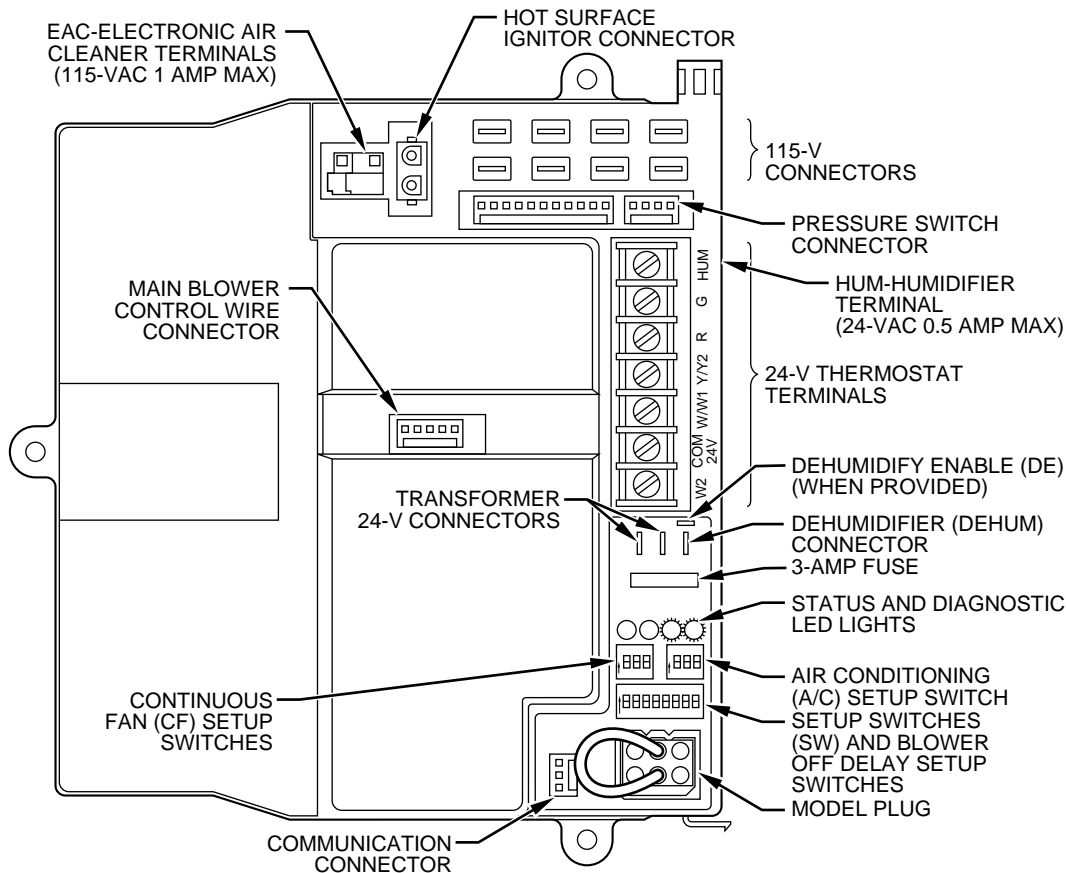

→ Fig. 12—Variable-Capacity Control Center

A98296

- g. Manually close blower access panel door switch. Use a piece of tape to hold switch closed.

WARNING: Blower access panel door switch opens 115-v power to control center. No component operation can occur. Caution must be taken when manually closing this switch for service purposes. Failure to follow this warning could result in personal injury or death.

WARNING: Blower access panel door switch opens 115-v power to control center. No component operation can occur. Caution must be taken when manually closing this switch for service purposes. Failure to follow this warning could result in personal injury or death.

- h. After fault code 11 flashes for at least 2 times, remove R, W, and Y jumpers.
- i. Turn setup switch SW-1 to OFF position.
- j. Release blower access panel door switch and replace blower access panel.
- k. Operate furnace through 1 heat cycle to check for proper operation and check LED status.
- l. If furnace is operating properly and LEDs indicate proper operation, replace main furnace door.
3. The control can also assist in troubleshooting by performing a Component Test. The Component Test will functionally operate all furnace components, except the gas valve.
- a. To initiate Component Test proceed with the following:
- (1.) Leave 115-v power to furnace turned on.
 - (2.) Remove main furnace door.
 - (3.) Remove blower access panel.
 - (4.) Turn setup switch SW-6 to ON position.
 - (5.) Manually close blower access panel door switch. Use a piece of tape to hold switch closed.

- b. When items (1) through (5) above have been completed, the following will occur:

- (1.) The control center goes through a brief self test. This self test takes approximately 2 sec to complete. After door switch is closed, red (microprocessor) LED briefly comes on. Then green LED comes on for 1 sec, followed by 1 sec where both the green and yellow LEDs are on. During this time, the control is checking itself.
- (2.) Inducer motor operates for 20 sec at low speed, operates for 20 sec at high speed, then turns off.
- (3.) Hot surface ignitor is energized for 15 sec, then de-energized.
- (4.) Main blower motor operates for 20 sec at low speed, operates at high speed for 20 sec, then turns off.
- (5.) After component operation test is completed, 1 or more fault codes (11, 22, 41, or 42) will flash. See service label on back of main furnace door or Fig. 15 for explanation of codes.

NOTE: To repeat component test, turn setup switch SW-6 to OFF and then back to ON.

- c. After component test, perform the following:

- (1.) Release blower access panel door switch and turn setup switch SW-6 to OFF position.
- (2.) Replace blower access panel.
- (3.) Operate furnace through 1 heat cycle to check for proper operation and check LED status.
- (4.) If furnace is operating properly and LEDs indicate proper operation, replace main furnace door.

IX. CHECKING HEAT TAPE OPERATION (IF APPLICABLE)

In applications where the ambient temperature around the furnace is 32°F or lower, freeze protection measures are required. If this application is where heat tape has been applied, check to ensure it will operate when low temperatures are present.

NOTE: Heat tape, when used, should be wrapped around the condensate drain trap and drain line. There is no need to use heat tape within the furnace casing. Most heat tapes are temperature activated, and it is not practical to verify the actual heating of the tape. Check the following:

1. Check for signs of physical damage to heat tape such as nicks, cuts, abrasions, gnawing by animals, etc.
2. Check for discolored heat tape insulation. If any damage or discolored insulation is evident, replace heat tape.
3. Check that heat tape power supply circuit is on.

X. WINTERIZING

⚠	CAUTION: Freezing condensate left in the furnace will damage the equipment.
---	--

If the furnace will be off for an extended period of time in a structure where the temperature will drop to 32°F or below, winterize as follows:

1. Turn off electrical supply to furnace.
2. Remove main furnace door.
3. Disconnect drain tube from inducer housing. (See Fig. 13.)

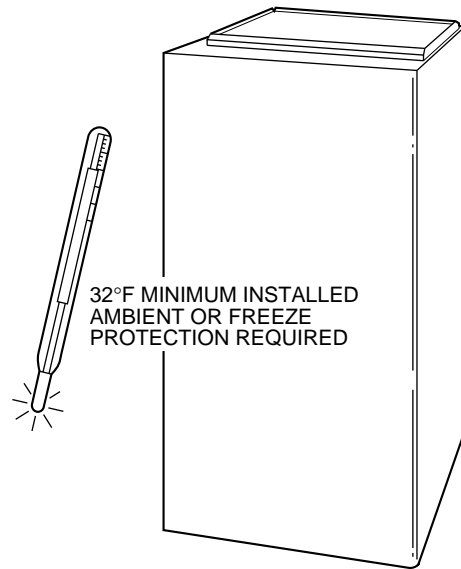

A93058

⚠	CAUTION: If this furnace is installed in an unconditioned space where the ambient temperatures may be 32°F or lower, freeze protection measures must be taken.
---	---

4. Insert funnel in drain tube and pour antifreeze, propylene glycol (RV, swimming pool antifreeze, or equivalent) into furnace until it is visible at point where condensate enters open drain. (See Fig. 14.)
5. Reconnect drain tube to inducer housing.
6. Replace main furnace door.

CAUTION: Do not use ethylene glycol (Prestone II antifreeze/coolant or equivalent automotive type). Failure of plastic components will occur.

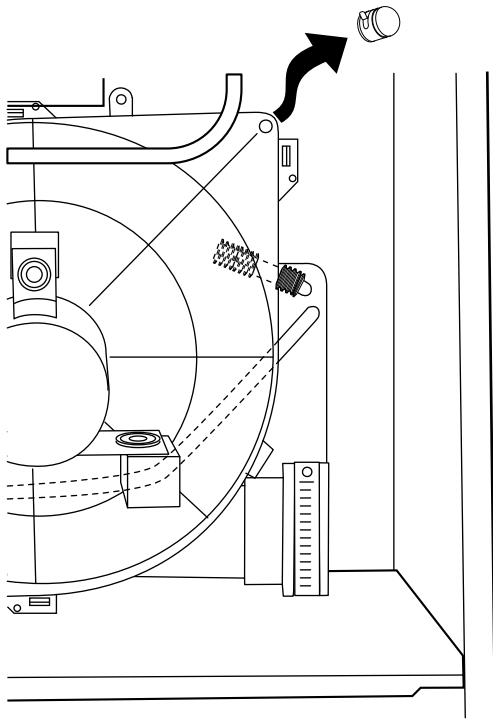

Fig. 13—Inducer Housing Drain Tube

A94208

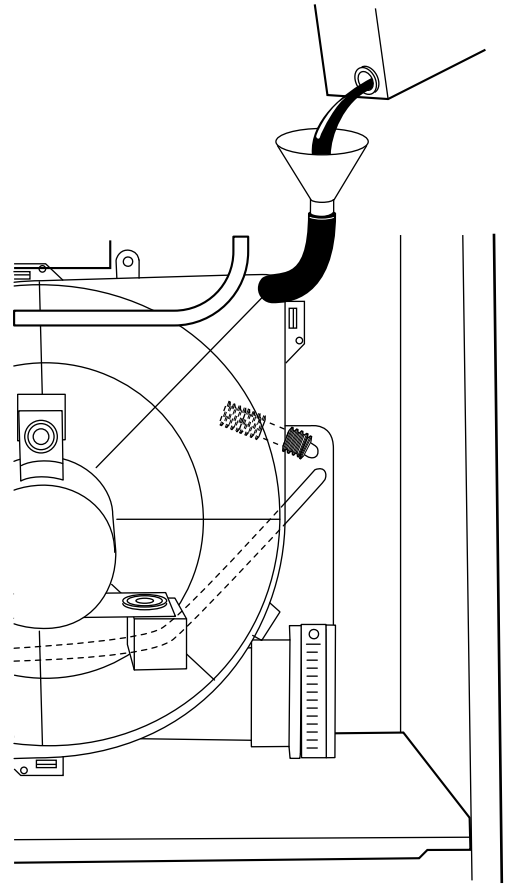

Fig. 14—Funnel in Drain and Antifreeze Running Through Trap

A94209

SERVICE

LED CODE

RED LED1 ON
RED LED2 ON

STATUS

Furnace is operating in emergency heat.
The microprocessor has malfunctioned. To reset: Put setup switch "SW-1" in the "ON" position and jumper thermostat terminals "R", "W/W1", and "Y/Y2" simultaneously with the door switch pushed in and power to the unit "ON". Disconnect jumper and place setup switch in the "OFF" position. If LED2 reappears replace main control board.

YELLOW LED3 ON
GREEN LED4 ON
RED LED2 FLASHING

Furnace is operating in high heat.
Furnace is operating in low heat.
Line voltage polarity is reversed.

EACH OF THE FOLLOWING STATUS CODES IS A TWO DIGIT NUMBER WITH THE FIRST DIGIT DETERMINED BY NUMBER OF FLASHES OF THE YELLOW LED AND THE SECOND DIGIT DETERMINED BY NUMBER OF FLASHES OF THE GREEN LED.

- 11 NO FAULT IN RECENT HISTORY DISPLAY** - Indicates no faults have occurred within last five cycles. To read recent fault history put setup switch "SW-1" in the "ON" position. To clear recent fault history, put setup switch "SW-1" in the "ON" position and jumper thermostat terminals "R", "W/W1", and "Y/Y2" simultaneously until an "11" is flashed.
- 12 BLOWER CALIBRATION LOCKOUT** - Indicates RPM calculated for low heat was less than 250 RPM or greater than 1300 RPM on two successive attempts. Auto reset after three hours. Reset power and refer to fault #44 section.
- 13 LIMIT SWITCH LOCKOUT** - Indicates the occurrence of 10 successive limit trips during high heat or three successive limit trips during low heat. Auto reset after three hours.
Check for:
- Improper or misaligned limit and/or limit shield.
- Improper high or low heat gas input adjustment.
- Stuck high heat solenoid in gas valve.
- 14 IGNITION LOCKOUT** - Control will auto-reset after three hours. Refer to #34.
- 21 INVALID MODEL SELECTION** - Indicates model plug is missing or incorrect. See wiring diagram for correct connector/jumper location.
- 22 SETUP ERROR** - Indicates setup switch "SW-1" or SW-6" is positioned improperly. The following combinations will cause the fault:
- Thermostat call with "SW-1" "ON".
- Thermostat call with "SW-6" "ON".
- "SW-1" and "SW-6" both "ON" together.
- 23 INVALID BLOWER AIRFLOW SELECTION** - Indicates improper "A/C" or "CF" switch setting. The 042 and 14 units can deliver 1-1/2 to 3-1/2 tons A/C and 600 to 1400 CFM for continuous fan. The 060 and 20 unit can deliver 2 to 5 tons A/C and 800 to 2000 CFM for continuous fan. If code is flashing unit will default to closest allowable airflow.
- 24 SECONDARY VOLTAGE FUSE IS OPEN** - Indicates the fuse is open and there is a short circuit in the low voltage wiring.
- 31 HIGH PRESSURE SWITCH FAULT** - Indicates high pressure switch is closed at call, or in low heat, or fails to close after call, or opens in high heat.
Check for:
- Plugged condensate drain.
- Water in vent piping, possibly sagging pipe.
- Improper pressure switch wiring or pressure switch tubing connections.
- Failed or "Out-of-Calibration" pressure switches.
- 32 LOW PRESSURE SWITCH FAULT** - Indicates low pressure switch is closed at call, or fails to close after call, or opens during operation.
Check for:
- Plugged condensate drain.
- Water in vent piping, possibly sagging pipe.
- Improper pressure switch wiring or pressure switch tubing connections.
- Failed or "Out-of-Calibration" pressure switches.
- 33 LIMIT SWITCH FAULT** - Indicates the limit, rollout switch or auxiliary limit switch is open or the unit is operating in high heat only mode due to two successive low heat limit trips.
Check for:
- Improper or misaligned limit and/or limit shield.
- Improper low heat gas input adjustment.
- Stuck high heat solenoid in gas valve.

34 IGNITION PROVING FAULT - Control will try three more times before a lockout #14 occurs.

- Check for:
- Gas valve turned "OFF".
 - Oxide buildup on flame sensor (clean with fine sandpaper.)
 - Main shutoff valve turned "OFF".
 - Green wire **MUST** be connected to furnace sheet metal.
 - Proper flame sense microamps (.5 microamps D.C. minimum)
 - Inadequate flame carryover or rough ignition.

41 BLOWER OUTSIDE VALID SPEED RANGE - Indicates the blower is not operating at the calculated RPM. If this fault occurs in conjunction with fault #44 check wiring to motor otherwise refer to the trouble-shooting guide.

42 INDUCER OUTSIDE VALID SPEED RANGE - Indicates the inducer is not operating at the calculated RPM, or has not started within 10 seconds after a call for heat. Check wiring to motor otherwise refer to the trouble-shooting guide.

43 PRESSURE SWITCH CALIBRATION FAULT - Indicates the low and high pressure switch "make" points during high heat purge are not within the calibration range.

- Check for:
- Plugged condensate drain.
 - Water in vent piping, possibly sagging pipe.
 - Improper pressure switch wiring or pressure switch tubing connections.
 - Failed or "Out of Calibration" pressure switches.

44 BLOWER CALIBRATION FAULT - Indicates the calculated blower speed is below 250 or above 1300 RPM. Unit will default to low or high heat mode if possible. If this fault occurs in conjunction with fault #41 check wiring to motor otherwise refer to the trouble-shooting guide. If this fault occurs by itself check for undersized ductwork, or excessive static caused by a dirty filter, or closed registers.

STATUS CODE EXAMPLE

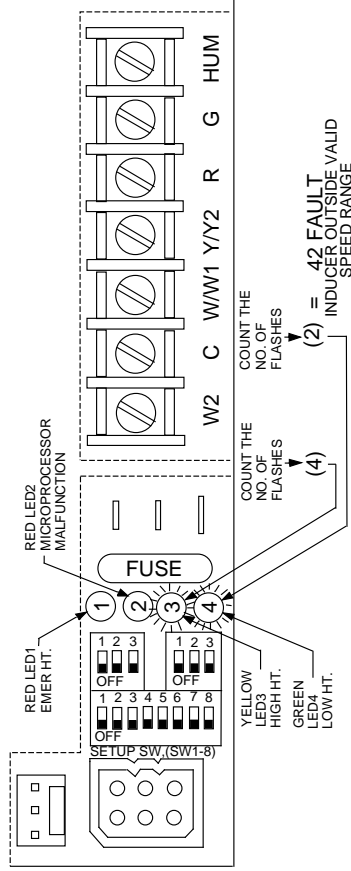

COMPONENT TEST

To initiate the component test sequence, shut "OFF" the room thermostat or disconnect the "R" thermostat lead. Put setup switch "SW-6" in the "ON" position to start the component test sequence. Once initiated the main board will turn "ON" the inducer motor-low speed, inducer motor-high speed, hot surface ignitor, blower motor-low speed, and blower motor-high speed for 15-20 seconds each. When component test is completed one or more of the following codes will flash.

CODE

- 11** Indicates inducer and blower motor tested OK. Visual check of hot surface ignitor required.
- 22** **SETUP ERROR** - Same as code 22 above.
- 41** **BLOWER OUTSIDE VALID SPEED RANGE** - Indicates blower motor failed test. Check blower, wiring, and control center.
- 42** **INDUCER OUTSIDE VALID SPEED RANGE** - Indicates inducer motor failed test. Check inducer, wiring and control center.

DESCRIPTION

- 11** Indicates inducer and blower motor tested OK. Visual check of hot surface ignitor required.
- 22** **SETUP ERROR** - Same as code 22 above.
- 41** **BLOWER OUTSIDE VALID SPEED RANGE** - Indicates blower motor failed test. Check blower, wiring, and control center.
- 42** **INDUCER OUTSIDE VALID SPEED RANGE** - Indicates inducer motor failed test. Check inducer, wiring and control center.

To repeat component test turn setup switch "SW-6" "OFF" and then back "ON". After component test is completed put setup switch "SW-6" in the "OFF" position and reconnect the "R" thermostat lead.

320624-101 REV. E

Fig. 15—Service Label

SERVICE TRAINING

Packaged Service Training programs are an excellent way to increase your knowledge of the equipment discussed in this manual, including:

- Unit Familiarization
- Maintenance
- Installation Overview
- Operating Sequence

A large selection of product, theory, and skills programs is available, using popular video-based formats and materials. All include video and/or slides, plus companion book.

Classroom Service Training plus "hands-on" the products in our labs can mean increased confidence that really pays dividends in faster troubleshooting, fewer callbacks. Course descriptions and schedules are in our catalog.

CALL FOR FREE CATALOG 1-800-962-9212

Packaged Service Training

Classroom Service Training

A94328

